

it in a form in which it can be naturally included partly in the free-electron energy and partly in the electrostatic energy. That term never appears explicitly in the present treatment because of our choice of a Hermitian w in Eq. (15). Thus, we now have a different effective charge for the electrostatic energy, which is equal to the charge

on the ion plus the orthogonalization charge at each ion. In addition, the free-electron energy is simpler in form. The separation given here, which is the same as that used by Pick and Sarma,⁴ seems much more natural than the one that we used earlier, though the total energy is the same in either case.

Knight Shifts and Susceptibilities of Transition Metals: Palladium*

J. A. SEITCHIK, A. C. GOSSARD, AND V. JACCARINO

Bell Telephone Laboratories, Murray Hill, New Jersey

(Received 17 June 1964)

The nuclear magnetic resonance (NMR) of Pd¹⁰⁵ has been observed for the first time. The temperature dependence of the Pd¹⁰⁵ NMR in palladium metal was studied in the region 1.4 to 300°K. The relatively large linewidth ($\delta H = 9 \pm 2$ Oe) at all temperatures necessitated the use of continuous averaging techniques to obtain the requisite sensitivity. The field for resonance, at a fixed frequency, was found to have a maximum in the vicinity of 85°K, as does the susceptibility $\chi(T)$. From an analysis of the temperature dependence of the Knight shift $K(T)$ and of $\chi(T)$ it was deduced that: (1) d -spin paramagnetism is responsible for the observed behavior of $K(T)$ and $\chi(T)$, (2) the principle contribution to K in Pd arises from d -spin-induced core polarization and (3) the core-polarization hyperfine field $H_{ep} = -689 \pm 20$ kOe/spin. From a partitioning of the various contributions to K , χ , and the specific heat, an estimated value of $1/T_1 \simeq 0.8T \text{ sec}^{-1} \text{ }^\circ\text{K}$ is obtained for the nuclear spin-lattice relaxation rate at low temperatures. It is shown that the "knee" in $\chi(T)$ is *not* associated with a static antiferromagnetic ordering; an upper limit of $10^{-5} \mu_B$ per Pd atom for the spontaneous moment at low temperatures is obtained. A diamagnetically uncorrected value of the Pd¹⁰⁵ nuclear moment $\mu^{105} = -0.639 \pm 0.003 \text{ nm}$ was determined.

1. INTRODUCTION

THE large electronic specific heat C_v and susceptibility χ of palladium metal has been a subject of some interest for many years.¹⁻⁵ From AgPd alloying studies it has been advanced that the $4d$ band is shy 0.4 to 0.6 of an electron of being completely filled. The relatively large observed values of the electronic specific heat and the susceptibility have been associated with the combined effects of a large value of the density of states at the Fermi level in the d band $N_d(E_F)$ and a sizeable intraband exchange interaction.

Of particular interest is the behavior of the temperature dependence of χ , for it is found² that $\chi(T)$ exhibits a pronounced maximum in the vicinity of 85°K. This, and the fact that magnetic impurity studies have

shown⁶⁻⁸ Pd to be an extremely polarizable metal have quite naturally led to the belief⁹ that an ordered antiferromagnetic spin state occurs below 85°K. Alternatively it has been suggested⁴ that the anomalous peak in $\chi(T)$ could be obtained from an unusual shape to the density-of-states curves in the region of the Fermi level. Recent precise calorimetric measurements¹⁰ have shown there is no measurable specific-heat anomaly at the temperature corresponding to the maximum in $\chi(T)$ as would be expected from a second-order transition. In addition neutron diffraction measurements¹¹ have established that at low temperatures the spontaneous moment per Pd atom must be less than 0.03 Bohr magnetons. Observations of the nuclear magnetic resonance (NMR) of Pd¹⁰⁵ in Pd metal at low temperatures indicated that the upper limit on the magnetic moment per atom must be several orders of magnitude smaller than that which is deduced from the neutron experiments. (We will discuss the meaning of the latter two experiments later on.) Thus it appears there is little to support the conjecture of antiferromagnetism in Pd metal.

* A preliminary report of portions of this work has been given previously, A. C. Gossard and V. Jaccarino, *Bull. Am. Phys. Soc.* **7**, 556 (1962).

¹ N. F. Mott and H. Jones, *The Theory of the Properties of Metals and Alloys* (Clarendon Press, Oxford, England, 1936).

² F. E. Hoare and J. C. Matthews, *Proc. Roy. Soc. (London)* **A212**, 137 (1952); D. Budworth, F. Hoare, and J. Preston, *ibid.* **A257**, 250 (1960).

³ A. J. Manuel and J. M. P. St. Quinton, *Proc. Roy. Soc. (London)* **A273**, 412 (1963).

⁴ E. W. Elcock, P. Rhodes, and A. Teviotdale, *Proc. Roy. Soc. (London)* **A221**, 53 (1954).

⁵ M. Shimizu, *J. Phys. Soc. Japan* **16**, 1114 (1961). References to other theoretical work are given in this article.

⁶ F. W. Constant, *Phys. Rev.* **36**, 1654 (1930).

⁷ D. Gerstenberg, *Ann. Physik* **2**, 236 (1958).

⁸ J. Crangle, *Phil. Mag.* **5**, 335 (1960).

⁹ A. B. Lidiard, *Proc. Roy. Soc. (London)* **A224**, 161 (1954).

¹⁰ J. Crangle and T. F. Smith, *Phys. Rev. Letters* **9**, 86 (1962).

¹¹ S. C. Abrahams, *Phys. Chem. Solids* **24**, 589 (1963).

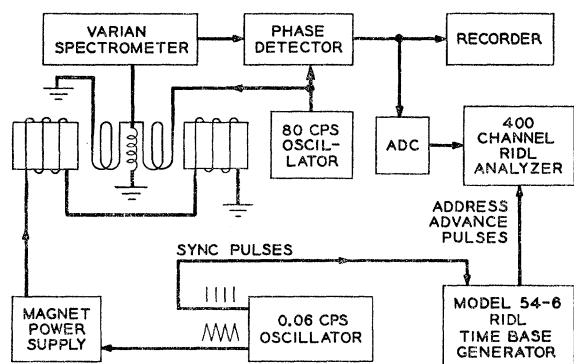

FIG. 1. A block diagram of the experimental apparatus showing the use of the multichannel analyzer for continuous averaging as used to supplement conventional detection techniques.

The present work extends the observations of NMR in Pd metal from 4.2 to 293°K. The shift in the field for resonance at a fixed frequency is found to be temperature-dependent, passing through a *maximum* in the same region where the susceptibility has its *maximum*. A comparison of the two measurements, with temperature the implicit parameter, shows that the Knight shift and χ are linearly related. From this relation the magnitude and sign of the hyperfine field resulting from core polarization of inner shell *s* electrons by the spin paramagnetism of the *4d* band electrons may be determined.

Since the magnitude of the Pd¹⁰⁵ nuclear magnetic moment was previously known¹² to an accuracy of only $\pm 10\%$, it is not possible to determine an exact value for the Pd metal Knight shift. However, from the observed temperature dependence of the NMR and χ and using reasonable estimates for *s* conduction electron and *d* band orbital contributions to the Knight shift and susceptibility, we may determine a value of the nuclear moment of Pd¹⁰⁵ with an accuracy of $\pm 0.4\%$.

2. EXPERIMENTAL DETAILS

The sample material consisted of particles, less than 0.04 mm in their largest dimension, obtained from 99.999% pure Pd sponge.¹³ Measurements at 4.2, 20.4, and 77°K were made by inserting the sample directly in a bath of liquid helium, hydrogen, and nitrogen, respectively. To achieve temperatures intermediate to the region 90–300°K a Varian No. 4540 temperature control unit was utilized. A crossed coil spectrometer was used for the NMR measurements along with a conventional electromagnet.

When intensity considerations permitted, resonances were observed by displaying the spectrometer's output directly on a strip chart recorder. Above 20°K, the Pd¹⁰⁵ NMR was not sufficiently intense to permit

observation by this conventional detection scheme. An enhancement of the signal-to-noise ratio was obtained by the method of continuous averaging.¹⁴ In this method, one repeatedly sweeps through the resonance, obtaining many traces of a resonance buried in noise. The traces are then summed to form a composite picture of a clearly observable resonance. The summation may be performed automatically by storing each trace in the memory of a multichannel analyzer.

To accomplish this (see Fig. 1) a periodic voltage was injected into the current regulating circuit of the electromagnet's power supply. Magnetic field sweeps of about 200 G were obtained using a triangular wave with frequency of 0.06 cps. The oscillator supplying the wave form also provided synchronization pulses marking the initiation of each cycle. The synchronization pulse triggered a timing circuit which provided a cycle of 400 pulses, each separated by 40 msec. Each of these pulses advanced, by one unit, the address of a 400 channel multichannel analyzer. Thus the analyzer completely passed through its 400 channels $\frac{2}{3}$ of a second before the next synchronization pulse reinitiated the cycle. This established a correspondence between channel address and the instantaneous magnetic field. During each of the 40-msec periods allotted to an analyzer channel, the output voltage of the spectrometer's phase detector was sampled by an analog-to-digital converter. The converter pulses were then added to the counts already

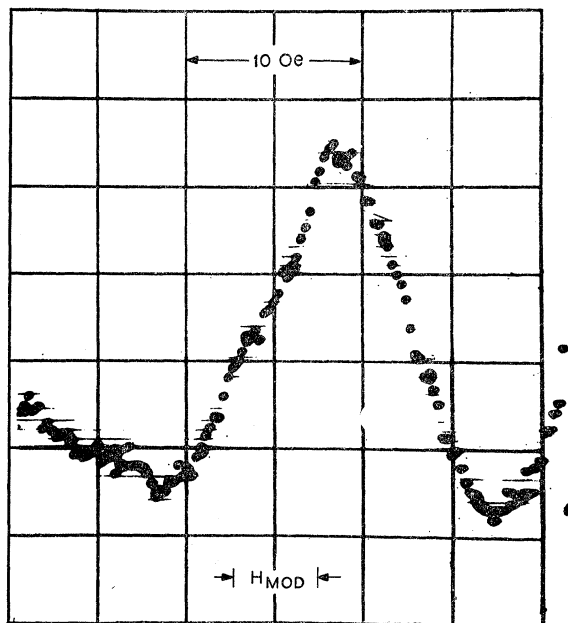

FIG. 2. An oscilloscope photograph of the derivative of the Pd¹⁰⁵ dispersion curve in palladium metal at 295°K after 360 cycles of the magnetic field through resonance. The lock-in amplifier preceding the analyzer had a 0.8-sec time constant. Only 100 of the analyzer 400 channels are displayed on the photograph.

¹² A. Steudel, Z. Physik 133, 438 (1952).

¹³ United Mineral and Chemical Corporation, New York, New York.

¹⁴ M. P. Klein and G. W. Barton, Jr., Rev. Sci. Instr. 34, 754 (1963).

stored in the memory for that channel of the analyzer. After one pass through the 400 channels the memory contained a digitalized form of the trace that would have been observed if the phase detector output had been displayed on a recorder. Most important is that after n complete cycles the signal-to-noise ratio has increased by \sqrt{n} .¹⁴ Figure 2 is an oscilloscope photograph of the Pd NMR at 293°K after 360 cycles of the magnetic field through resonance.

3. EXPERIMENTAL RESULTS

Temperature Dependence of the Field for Resonance

With the spectrometer frequency held at 2.6830 Mc/sec, the field for the Pd¹⁰⁵ resonance at the various temperatures was determined, using a proton NMR field measuring probe. As shown in Fig. 3, the field for resonance H was strongly temperature-dependent, rising to a maximum in the vicinity of 85°K where the magnetic susceptibility of Pd metal also exhibits a maximum.² As shown in Fig. 4, a plot of H versus χ , with temperature as an implicit variable, is a straight line. The extrapolated intercept H_i of this line with the H axis occurs at a field of $13\,666 \pm 14$ Oe.

Linewidths and Intensities

At all temperatures it was possible to observe the dispersion signals of the Pd NMR at high rf levels. By contrast, the absorption signal was visible only above 100°K under these same conditions. Estimates of the nuclear spin lattice relaxation time T_1 (see Sec. 5) indicated that the absorption signal would not saturate below 20°K provided H_{rf} did not exceed 40 mOe.

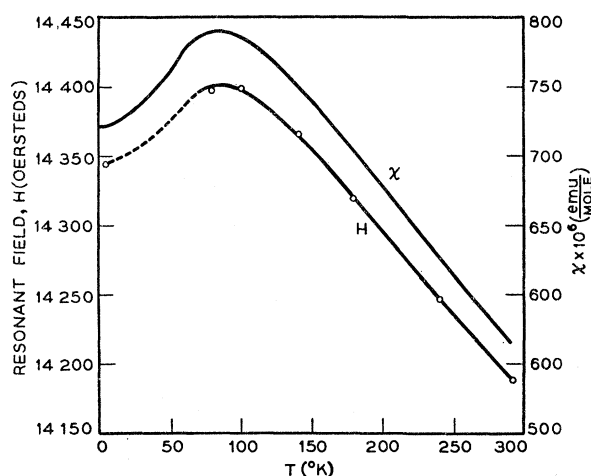

FIG. 3. The experimentally observed field for resonance, at a fixed frequency of $\nu = 2.6830$ Mc/sec, for the Pd NMR in palladium metal as a function of temperature. The measurement of the temperature dependence of the susceptibility by Hoare and collaborators (see Ref. 2) showing the familiar "knee" at approximately 85°K is shown as well.

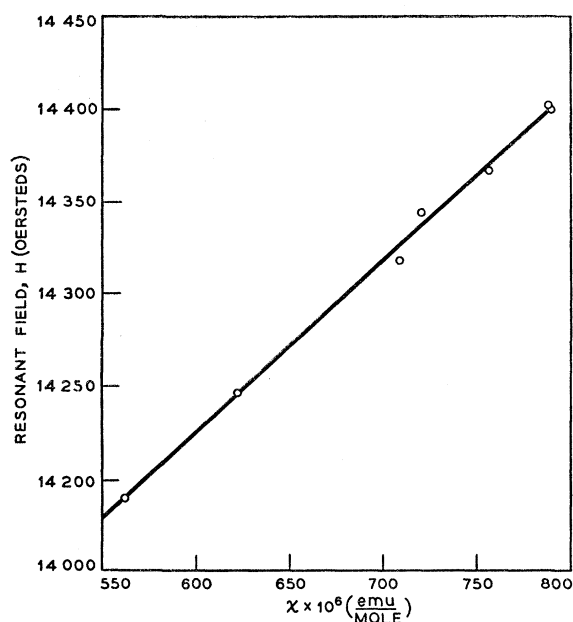

FIG. 4. The experimentally observed field for resonance of the Pd¹⁰⁵ NMR in palladium metal versus the susceptibility with temperature the implicit variable.

Indeed at very low rf power levels an absorption signal was observed at temperatures as low as 4.2°K.

The separation between the extrema of the derivative of the absorption signal δH was found to vary insignificantly from 4.2 \leftrightarrow 300°K; in this range $\delta H \sim 9 \pm 2$ Oe. It is estimated that the random shapes of the particles and the high susceptibility of palladium results in a demagnetization broadening of approximately 4 Oe at 15 kOe.¹⁵ Since the susceptibility changes by more than 25% between 80 and 300°K and no corresponding change was observed in δH , it appears that this cannot be the major source of linewidth.

Nuclear dipolar broadening accounts for less than $\frac{1}{3}$ Oe of linewidth. Consideration of the high purity of the sample would suggest magnetic impurities make a negligible contribution to δH . Similarly, the long T_1 , particularly at low temperatures, would indicate "lifetime" effects to be of little consequence. It was therefore concluded that the major part of the observed linewidth is associated with either a spatial variation of the Knight shift or quadrupolar broadening resulting from strains, dislocations or imperfections in the samples; the latter being the most probable of the two since δH was not dependent on χ .

No attempt was made to examine the field dependence of the linewidth or intensity since the operating

¹⁵ L. E. Drain, Proc. Phys. Soc. (London) **80**, 1380 (1962). It appears from NMR measurements that we have made in platinum metal that the demagnetizing broadening that one would expect in a sponge somewhat exceeds the estimates given in this reference. Our value of $\delta H = 4$ Oe is obtained by scaling the platinum measurements from a comparison of the susceptibilities of the two metals.

field (≈ 15 kOe), approximately the *maximum* field available, already corresponded to the *lowest* frequency at which the NMR spectrometer could be operated. This unfortunate circumstance made it impossible to distinguish between these various contributions to the linewidth.

Clearly more detailed studies of line shapes and intensities are indicated; they must await the availability of much higher fields for NMR studies.

In measuring intensities and linewidths, difficulties were encountered insofar as the signal amplitude varied in samples obtained at different times from the same source as well as in any one sample if it was "contaminated." In particular it was noted that the resonance intensity deteriorated in samples accidentally exposed to hydrogen gas at room temperature.¹⁶ Deliberate hydrogenation of the Pd obliterated the resonance, a fact that was ascertained by searching for a broad line over an extended range ($\pm 10\%$) of magnetic fields centered about the intercept field H_i , with no success.

4. INTERPRETATION

Contributions to the Susceptibility and Knight Shift

Susceptibility

The procedure we will follow for interpreting the temperature dependence of the NMR and the susceptibility in palladium parallels that previously used for platinum¹⁷; a simplified two-band (d and s) model is assumed to describe the spin paramagnetism of the conduction electrons. The s electrons are treated as free electrons ($m^*=m$) and a tight-binding approximation made for the d electrons; the latter assumption is particularly useful for estimating the orbital paramagnetism of the incompletely filled degenerate d band. The total susceptibility χ may be expressed as

$$\chi(T) = \frac{2}{3}\chi_{\text{P}}^s + \chi_{\text{P}}^d(T) + \chi_{\text{VV}} + \chi_{\text{dia}}, \quad (1)$$

where χ_{P}^s and $\chi_{\text{P}}^d(T)$ are the Pauli spin susceptibilities of the s and d electrons, respectively. The latter is assumed to be a function of temperature because of a sizeable variation of the density of states $N(E)$ with energy in the vicinity of the Fermi level E_F . A further enhancement of the temperature dependence of χ_{P}^d will result from the exchange interaction between the d holes.

The factor $\frac{2}{3}$ represents the correction to χ_{P}^s for the Landau diamagnetism χ_{L}^s ; i.e., $\chi_{\text{L}}^s = -\frac{1}{3}\chi_{\text{P}}^s$ when $m^*=m$. Because the d electrons have a large effective mass $\chi_{\text{L}}^d \ll \chi_{\text{P}}^d$ we may safely neglect χ_{L}^d . χ_{VV} is the ana-

log in degenerate-band metals¹⁸ of the familiar Van Vleck temperature-independent orbital susceptibility. χ_{dia} includes all of the diamagnetic susceptibility of the core electrons plus the *filled* portion of the d band.

χ_{P}^s : It has been determined^{19,2,5} previously that n_d , the number of d holes/atom in the unfilled Pd $4d$ band, is equal to 0.4–0.6. Since in our two-band model it is required that $n_d = n_s$, the number of s electrons/atom in the occupied part of the s band, we take $n_s = 0.5$ from which we obtain²⁰ $\chi_{\text{P}}^s = 6.2 \times 10^{-6}$ emu/mole.

χ_{dia} : A reasonable estimate for χ_{dia} is obtained by subtracting the free-electron spin susceptibility ($n_s = 1$) from the measured χ of Ag metal since for our purposes Pd ($Z=46$) and Ag ($Z=47$) differ only by the latter having the $4d$ band filled, $n_d = 0$. The value computed for χ_{dia} is -25×10^{-6} emu/mole.

χ_{VV} : In Pt, χ_{VV} was determined from a graphical analysis of Knight shift versus susceptibility, a procedure which we cannot use at present because the nuclear moment of Pd¹⁰⁵ has *not* been determined by observation of Pd¹⁰⁵ NMR in a nonmetallic, nonmagnetic reference and thus the "zero" of Knight shifts has not been established. (We discuss unsuccessful efforts to do so in Sec. 5.) Considering the qualitative similarities in the electronic properties of Pd and Pt alloys as indicating the respective $4d$ and $5d$ bands to be occupied to the same extent one would expect $(\chi_{\text{VV}})_{\text{Pd}} \approx 25 \times 10^{-6}$ emu/mole. Alternatively, by "scaling" the value previously determined for V metal according to the prescription¹⁷

$$(\chi_{\text{VV}})_{\text{Pd}} / (\chi_{\text{VV}})_{\text{V}} = (N_0 N_u)_{\text{Pd}} / (N_0 N_u)_{\text{V}},$$

where N_0 and N_u are the respective numbers of occupied and unoccupied states in the d band and $N_0 + N_u = 10$ /atom, one finds $(\chi_{\text{VV}})_{\text{Pd}} \approx 30 \times 10^{-6}$ emu/mole²¹; we take this latter value and assume it to be in error no more than $\pm 50\%$. Since $\frac{2}{3}\chi_{\text{P}}^s + \chi_{\text{dia}} + \chi_{\text{VV}} < 10 \times 10^{-6}$ emu/mole, whereas $\chi(T)$ is larger than 500×10^{-6} emu/mole below 300°K it is seen that for all practical purposes $\chi(T) = \chi_{\text{P}}^d(T)$.

Knight Shift

The three contributions to the Knight shift of the Pd¹⁰⁵ NMR are those arising from the s -conduction-electron contact hyperfine interaction, the polarization of the core electrons by the d spin moments, and the orbital hyperfine interaction associated with the field-induced orbital paramagnetism.

¹⁸ R. Kubo and Y. Obata, J. Phys. Soc. Japan **11**, 547 (1956).

¹⁹ P. Wohlforth, Proc. Leeds Phil. Soc. **5**, 89 (1948).

²⁰ The molar spin susceptibility is given by $\chi_{\text{P}}^s = 1.86 \times 10^{-6} \times (M/\rho)^{2/3} n_s^{-1/3}$, where for Pd the molecular weight $M = 106.4$ and the density $\rho = 12.16$ g/cm³.

²¹ We have used a value of $(\chi_{\text{VV}})_{\text{V}} = 150 \times 10^{-6}$ emu/mole which is an average of the value deduced from Knight shift studies [A. M. Clogston, A. C. Gossard, V. Jaccarino and Y. Yafet, Phys. Rev. Letters **9**, 262 (1962)] and that which was obtained from a simplified band calculation for chromium [J. S. Denbigh and W. M. Lomer, Proc. Phys. Soc. (London) **82**, 156 (1963)].

¹⁶ D. P. Smith, *Hydrogen in Metals* (Chicago University Press, Chicago, 1948).

¹⁷ A. M. Clogston, V. Jaccarino, and Y. Yafet, Phys. Rev. **134**, A650 (1964).

In terms of the corresponding susceptibilities the various contributions to the Knight shift may be expressed as¹⁷

$$K(T) = \alpha_s \chi_P^s + \alpha_d \chi_P^d(T) + \beta \chi_{VV}, \quad (2)$$

where α_s and α_d are 0.895×10^{-4} times the hyperfine fields per spin for the s contact and d core polarization processes, respectively, and $\beta = (2/A) \langle 1/r^3 \rangle_{\text{met}}$, all in the metal, and A is Avogadro's number. It remains to estimate α_s , α_d , and β .

α_s : Using a value of the nuclear moment $\mu_n^{105} = -0.639 \text{ nm}^{22}$ the optical hyperfine structure studies¹² of the transition $4d^9 5p \leftrightarrow 4d^9 5s$ yield a value of the free-atom $5s$ hyperfine field $H_{5s} = 9.21 \times 10^6 \text{ Oe}$. The s hyperfine field in the metal differs from that of the free atom, $H_s(\text{metal}) = \xi_s H_s(\text{atom})$; we use the experimentally determined value of $\xi_s = 0.7$ found for Ag as that appropriate to Pd. The uncertainty in the value of $\alpha_s = 5.8 \times 10^2$ thus determined arises principally from the uncertainty in ξ_s ; $K_s = 0.36\%$.

α_d : Since it is explicitly assumed in (1) and (2) that only χ_P^d is temperature-dependent it is to be expected that, as a function of temperature, K and χ will be linearly related. With the value of μ_n^{105} assumed, the experimentally observed fields for resonance may be

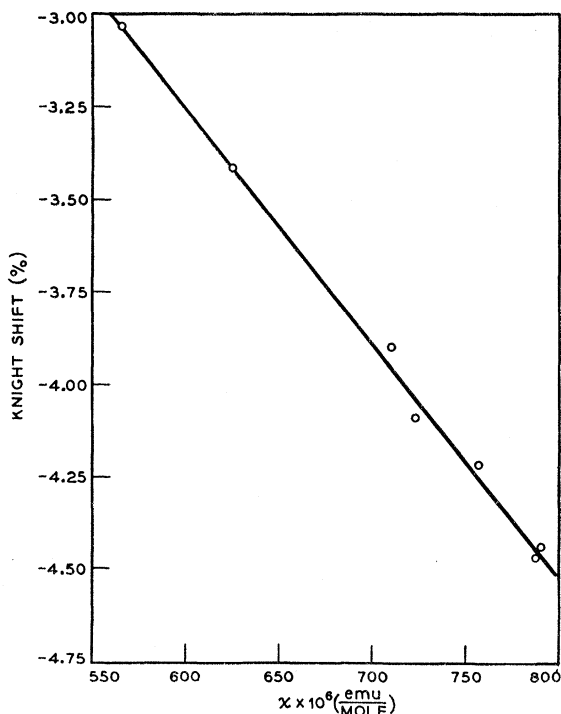

FIG. 5. The Knight shift of the Pd¹⁰⁵ NMR in palladium metal versus the susceptibility with temperature the implicit variable. The zero of the Knight shift scale is not precisely known because the nuclear moment of Pd¹⁰⁵ has been determined to an accuracy of only $\pm 0.4\%$.

²² The manner in which the nuclear moment was determined from our experiments is discussed in Sec. 5.

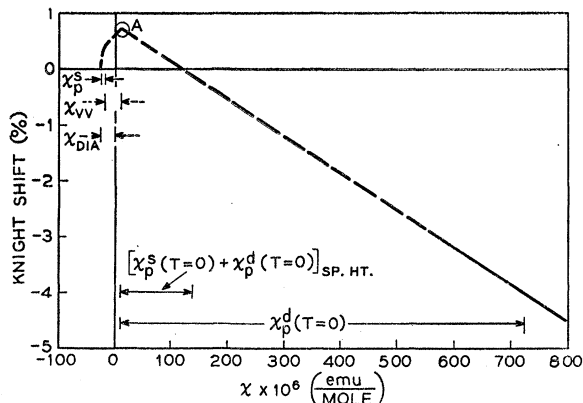

FIG. 6. A complete Knight shift versus susceptibility diagram for palladium metal. The solid line is the "observed" portion of the diagram shown in Fig. 5. The numerical details for constructing the diagram are given in the text. This figure should be compared with the corresponding one for platinum; Ref. 14, Fig. 2.

expressed as Knight shifts. The data of Fig. 4 replotted in this fashion are shown in Fig. 5 from which it is seen indeed that K and χ are linearly related. From the slope $\partial K(T)/\partial \chi(T)$ of the line which provides a best fit to the data, a value of $\alpha_d = -0.616 \times 10^2$ is obtained corresponding to a core polarization hyperfine field per spin in the metal of $H_{4d} = -0.689 \times 10^6 \text{ Oe}$. It is interesting to note that, as in Pt and V, the hyperfine field per spin produced by the d -band electrons is an order of magnitude smaller than, and opposite in sign to, that resulting from the s -band spin paramagnetism.

β : The optical data of the Pd^I hfs¹² do not determine the $4d$ orbital hyperfine field with sufficient accuracy for our purposes. However it is found that the values of $\langle 1/r^3 \rangle_{4d}$ computed from the theory of Breit and Wills,²³ and that deduced from recent Hartree-Fock calculations²⁴ ($\langle 1/r^3 \rangle_{4d} = 6.7$ and 7.3 a.u. , respectively), are in satisfactory agreement. We take $\langle 1/r^3 \rangle_{4d} = 7.0 \text{ a.u.}$ as a reasonable estimate and assume, as was done for²¹ V and Pt,¹⁷ that this value is reduced by some 25% in the metal. Thus $\langle 1/r^3 \rangle_{\text{met}} = 5.25 \text{ a.u.}$; $\beta = 1.19 \times 10^2$ corresponding to a hyperfine field per unit angular momentum of $0.66 \times 10^6 \text{ Oe}$ and $K_{VV} = +0.36\%$.

Construction of a K versus χ Diagram

A graphical representation of the various contributions to the Knight shift and susceptibility in palladium is shown in Fig. 6; the procedure follows that used previously for platinum.¹⁷

The estimated s spin and orbital contributions to K and χ are given by the dotted lines in the upper left-hand corner of the figure after having first corrected

²³ G. Breit and A. Wills, Phys. Rev. 44, 470 (1933); see also Ref. 12.

²⁴ A. J. Freeman and R. E. Watson (private communication). We are indebted to these authors for making their calculations of $\langle r^n \rangle$ available to us prior to publication.

for the core diamagnetism. The solid line in the lower right-hand corner is the experimentally observed K versus χ data shown in Fig. 5. Since the diagram must close on itself the solid line is extrapolated towards decreasing χ until it intersects the orbital contribution to K and χ at point A . In point of fact since the orbital contribution was estimated rather than "determined" by this procedure (as was the case in platinum) the relative position of the solid line on the ordinate scale was adjusted so that the extrapolation of the solid line would just coincide with the point A .

It is seen that the d -spin contribution to χ predominates over all others and that, as in platinum, the spin susceptibility is larger than the value $\chi_{\text{sp.ht.}}$ obtained from the measured electron specific heat.

5. ESTIMATE OF T_1 IN PALLADIUM

There are four independent interactions that contribute to the nuclear spin-lattice relaxation time T_1 in a transition metal; the contact hfs via the s -conduction electrons²⁵ and core polarization,²⁶ orbital,²⁷ and dipolar²⁷ interactions with the d -band electrons. The latter three are adequately described in the approximation of tight binding. It is found that for d electrons the dipolar interaction is some 25 times smaller than the orbital interaction and will therefore be neglected in an estimate of T_1 .

From the measured core polarization hyperfine field²⁸ $H_{\text{hf}}'(d)$ and the estimated values of $H_{\text{hf}}'(s)$ and $H_{\text{hf}}'(\text{orb})$ we may calculate the separate contributions to T_1 from the relations²⁶

$$\frac{1}{T_{1s}} = \frac{4\pi}{\hbar} [\gamma_n \hbar H_{\text{hf}}'(s)]^2 \left(\frac{\eta_s}{A}\right)^2 kT \equiv R_s T, \quad (3)$$

$$\frac{1}{T_{1\text{op}}} = \frac{4\pi}{\hbar} [\gamma_n \hbar H_{\text{hf}}'(d)]^2 \left(\frac{\eta_d}{A}\right)^2 kT \left[\frac{1}{3}f^2 + \frac{1}{2}(1-f)^2\right] \\ \equiv R_{\text{cp}} T \left[\frac{1}{3}f^2 + \frac{1}{2}(1-f)^2\right], \quad (4)$$

$$\frac{1}{T_{1\text{orb}}} = \frac{4\pi}{\hbar} [\gamma_n \hbar H_{\text{hf}}'(\text{orb})]^2 \left(\frac{\eta_d}{A}\right)^2 kT \left[\frac{2}{3}f(2-5/3f)\right] \\ \equiv R_{\text{orb}} T \left[\frac{2}{3}f(2-5/3f)\right], \quad (5)$$

where η_s and η_d are the density of states per mole for one direction of the spin and f is the fractional character of Γ_5 d orbitals at the Fermi surface. The total relaxation rate $1/T_1$ is obtained by adding (3), (4), and (5). Values of $R \equiv 1/T_1 T$ for two reasonable values of f for palladium are given in Table I along with other pertinent parameters.

It is interesting to note that, although core polariza-

TABLE I. Parameters used for evaluating the contributions to the Knight shift and nuclear relaxation time T_1 of the Pd^{105} NMR in Pd metal. The first column gives the hyperfine fields per electron in the metal. The second column gives the density of states at the Fermi surface for one direction of the spin using the measured total value $R/\eta = 12.3 \times 10^{11}$ cgs/atom and assuming the s part to be obtained from a free-electron estimate ($m/m^* = 1$, $n_s = 0.5$). The last column gave the separate contributions to the relaxation rates R_s , R_{cp} , and R_{orb} . The total relaxation rate R , including the core polarization and orbital reduction factors is given for two values of f , the fractional Γ_5 character to the d functions at the Fermi surface.

	$H_{\text{hf}}'(i)$ in 10^6 Oe	η_i/A in 10^{11} cgs/atom	R_i in sec^{-1} ($^\circ\text{K}$) ⁻¹
5s	3.22	0.64	0.12
4d(spin)	-0.345	11.7	0.45
4d(orbital)	0.664	...	1.65
			$R = 0.87$; $f = \frac{3}{5}$
			$R = 0.63$; $f = 1$

tion makes the major contribution to the Knight shift, it is the orbital interaction which dominates the nuclear relaxation rate. Unfortunately, no experimental measurement of T_1 in palladium has been made to date. It is expected that R will exhibit a stronger temperature dependence in palladium than was the case in platinum.²⁹

Nuclear Moment of Pd^{105}

Ideally the nuclear magnetic moment of any nuclide is obtainable from the observation of NMR in a nonmagnetic, nonmetallic liquid or solid containing the element of interest. Unfortunately, we have not been able to find NMR in such materials (e.g., chloropalladic acid³⁰) nor in many intermetallic compounds (e.g., Pd_2Si , PdGa , PdIn , etc.³¹) for which it might be assumed there would be neither d spin nor orbital contributions to the Knight shift. Nearly all of the intermetallic compounds had point symmetries lower than cubic at the Pd site and the absence of an easily detectable NMR in these metals could be attributed to a large nuclear electric quadrupole interaction.

Since only the NMR in palladium metal has been obtained, the following procedure was used to determine the moment. The field for resonance was extrapolated to zero susceptibility along the line shown in Fig. 3. The field intercept $\chi = 0$ was corrected for s and orbital Knight shifts. The value of the nuclear moment obtained is

$$\mu_n^{105} = -0.639 \pm 0.003 \text{ nm.}$$

When corrected for the diamagnetism of the core electrons³² we find

$$\mu_n^{105} = -0.642 \pm 0.003 \text{ nm.}$$

²⁹ See Sec. 4 and Fig. 3 of Ref. 26.

³⁰ We wish to thank J. P. Remeika for the preparation of the chloropalladic acid.

³¹ We wish to thank J. H. Wernick for the preparation of numerous palladium intermetallic compounds.

³² N. F. Ramsey, *Nuclear Moments* (John Wiley & Sons, Inc., New York, 1953), p. 86.

²⁵ J. Korringa, *Physica* **16**, 601 (1950).

²⁶ Y. Yafet and V. Jaccarino, *Phys. Rev.* **133**, A1630 (1964).

²⁷ Y. Obata, *J. Phys. Soc. Japan* **18**, 1020 (1963).

²⁸ We use the prime to denote field *per electron*; note that $H_{\text{hf}}'(d) = \frac{1}{2}H_{\text{hf}}(d)$, $H_{\text{hf}}'(s) = \frac{1}{2}H_{\text{hf}}(s)$, and $H_{\text{hf}}'(\text{orb}) = H_{\text{hf}}(\text{orb})$.

The sign was determined in our crossed coil spectrometer by comparing the phase of the Pd¹⁰⁵ signal with that of V⁵¹. The error indicated comes entirely from the accuracy adjudged in our extrapolation procedure. The uncorrected value obtained is to be compared with the optical hfs value³³

$$\mu_n^{105} = -0.61 \pm 0.04 \text{ nm.}$$

6. CONCLUSIONS

Absence of Antiferromagnetism

Apart from identifying the various contributions to the Knight shift and susceptibility, determining the nuclear moment of Pd¹⁰⁵ and estimating the nuclear relaxation time, the NMR experiment serves to eliminate the possibility of a *static* antiferromagnetic arrangement of the Pd spin moment as being the origin of the "knee" in χ versus T . If, as in a classical antiferromagnet, the "knee" arose from the fact that χ_1 is approximately independent of temperature below T_N and χ_{11} drops to zero monotonically in going from T_N to 0°K then one would expect in a randomly oriented powder that χ would have a maximum at $T \simeq T_N$. However, were this the case, then the d -spin Knight shifts parallel and perpendicular to the ordering direction would be different and, in our powdered samples, an increase in linewidth would result when $T < T_N$.

Assuming that the anisotropy in the susceptibility $\delta\chi$ would be associated with the d -spin paramagnetism then

$$\delta K_{cp}/K_{cp} = \delta\chi_p^d/\chi_p^d.$$

Since the increase in the linewidth at low temperatures at a field of 15 kOe is much less than 6 Oe while the core polarization shift at the same field is 600 Oe, it follows that

$$\delta\chi_p^d/\chi_p^d \ll 1\%.$$

³³ Two values of μ_n^{105} are obtained in Ref. 12 corresponding to distinct hyperfine structure observed on two different optical transitions. We are of the opinion that the data obtained from the transition $4d^9 5s^3 D_3 - 4d^9 5p^3 F_4$ is most easily interpretable and it is the value of μ_n^{105} so determined that is given.

Moreover, the appearance of a spontaneous moment $\langle S_z \rangle$ below T_N would cause the field for resonance to vary from $H_0 + H_{cp}\langle S_z \rangle$ to $H_0 - H_{cp}\langle S_z \rangle$. Since again no increase is observed in the linewidth δH at low temperatures

$$\langle S_z \rangle_{T \ll T_N} \ll \delta H / H_{cp} \simeq 10^{-5},$$

or the spontaneous magnetic moment does not exceed $10^{-5} \mu_B$.

We have employed the phrase *static* antiferromagnetic arrangement because one might conceive of an ordering in which the spins were reoriented in times short compared with the nuclear Larmor period, $T_L \simeq 10^{-7}$ sec. If this be the case the considerations on $\langle S_z \rangle_{T \ll T_N}$ mentioned above would not be applicable. The corresponding "observation" time in the neutron experiments is of the order of 10^{-11} sec. There is no evidence to date of any antiferromagnet, metallic or otherwise, having large fluctuations in $\langle S_z \rangle$ in such short times.

Thus, the rather stringent upper limits placed on the anisotropy in the susceptibility and the spontaneous moment at temperatures well below the "knee" force us to conclude that no magnetic ordering exists in palladium metal. More than likely the "knee" has its origin in the peculiarities in the structure of the density of states in the d band at energies close to the Fermi energy.

Enhancement of the d -Spin Susceptibility

The interpretation of the Knight shifts and susceptibility in palladium and the conclusion that the low-temperature behavior of $\chi(T)$ does not arise from magnetic ordering allows a comparison to be made of $\chi_d(T=0^\circ\text{K})$ and the corresponding value $\chi_{sp\cdot ht.}$ deduced from the low-temperature electron specific heat. (See discussion of Ref. 17, Sec. III.) The fact that $\chi_p^d(T=0) = 710 \times 10^{-6}$ emu/mole is some 5.6 times larger than $\chi_{sp\cdot ht.} = 127 \times 10^{-6}$ emu/mole indicates that the interaction between the d -band electrons is repulsive. As such, one would conclude that d -band superconductivity would not occur in palladium.